

### ISOL@MYRRHA

In parallel to the accelerator driven system (ADS) MYRRHA, plans are being developed at SCK•CEN for ISOL@MYRRHA: a radioactive ion beam (RIB) facility of the isotope separator on-line (ISOL) type focusing on fundamental science research. Using just a small fraction (< 5%, 100-200  $\mu\text{A}$ ) of the proton-beam intensity delivered by the MYRRHA accelerator, one can achieve production of high-intensity RIBs. Research fields which are typically addressed, are: nuclear, atomic and solid-state physics, fundamental-interactions studies and medical physics.

### Concept

ISOL@MYRRHA will follow closely the RIB production schemes that are developed and successfully used at the ISOLDE-CERN and TRIUMF facilities. It will be equipped with ruggedized target systems that allow the use of a selection of target materials, including actinide targets, which can withstand the proton-beam power ( $\sim 60$  kW) without compromising the reliability, the longevity, the diffusion and effusion properties, and the yield of particular radioactive isotopes.

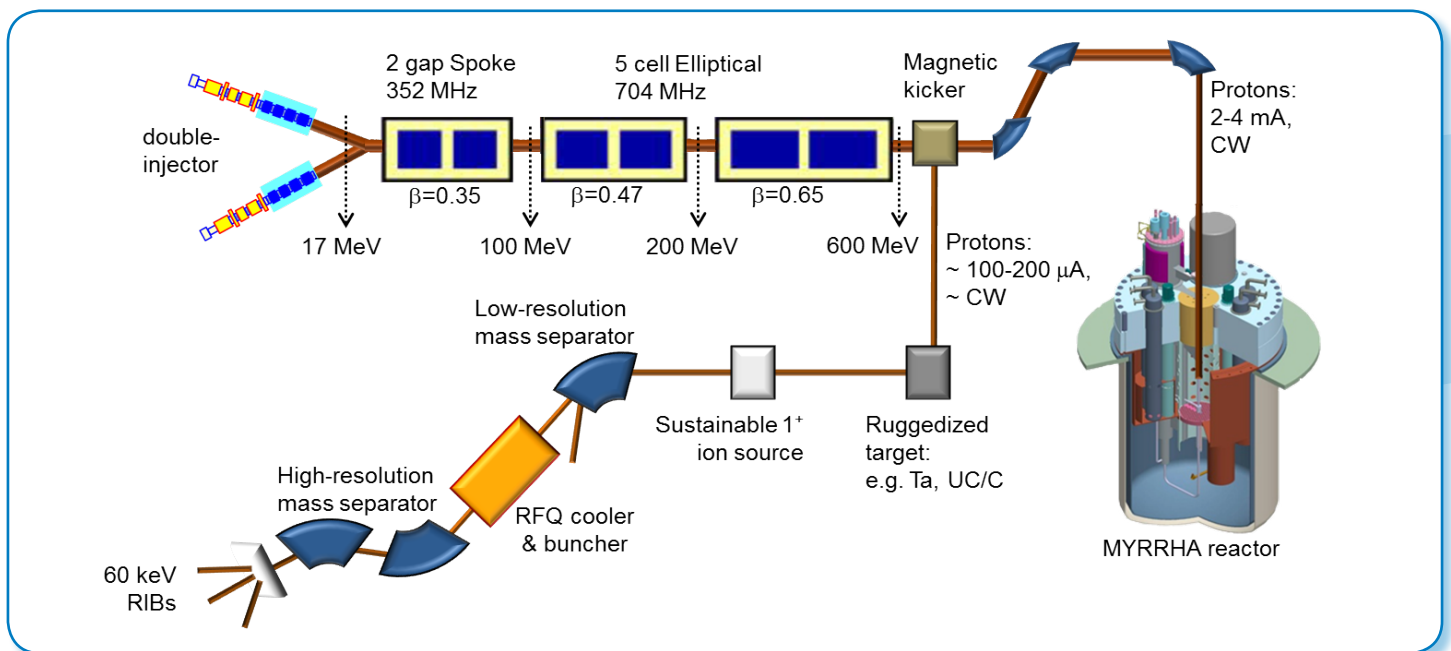

### Operational approach

The scenario to operate both MYRRHA and ISOL@MYRRHA in parallel, which requires a continuous beam splitter. A fraction of up to 5% of the main beam (corresponding to 100-200  $\mu\text{A}$  average current) will be delivered to ISOL@MYRRHA.

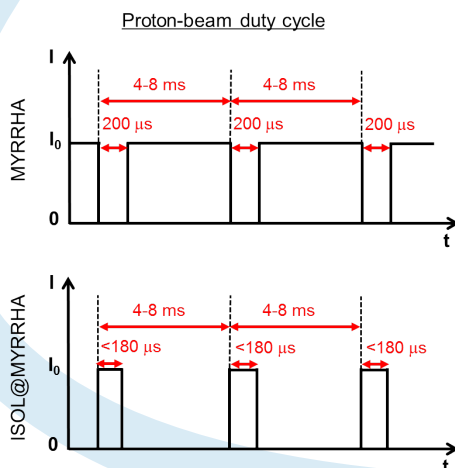

### Why ISOL@MYRRHA?

Radioactive ion beam research has been recognized as one of the top priorities in nuclear physics. Moreover, RIBs create a wide area of research opportunities in other fields. On the other hand, going more and more exotic is a driving incentive of several research programmes. Thus even vigorous efforts to improve beam intensity and purity, and detection efficiency and sensitivity will not substantially decrease the demand of beam time.

This limitation prohibits potentially very interesting programmes, involving experiments which:

- need very high statistics;
- need many time-consuming systematic measurements;
- hunt for very rare events;
- have an inherent limited detection efficiency.

These particular experimental programmes can be uniquely addressed at ISOL@MYRRHA, given the availability of extended beam times (several weeks up to months) with the high intensity and the high reliability of the MYRRHA accelerator.

## Ion sources

Three types of ion sources are foreseen for selective ionization of the products: the hot-surface ion source, the resonant ionization laser ion source (RILIS), and the electron cyclotron resonance ion source (ECRIS).

## Mass separators

Additional purification occurs by mass separation after extracting the ions over a potential difference of up to 60 kV forming the RIB.

In order to make effective use of the beam time, the parallel multi-users aspect of ISOL@MYRRHA is an important issue in the design study. Since a high-resolution mass separator prevents the use of different beams at the same time, a pre-separator with low-mass resolution is considered. In this way, one could envisage a scenario in which the lower-mass isotopes (e.g.  $^8\text{Li}$  for  $\beta$ -NMR in solid-state physics) are used in parallel with an experiment using heavier nuclei.

## Beam preparation

The pre-separation avoids a too intense RIB loading of the RFQ cooler and buncher, which allows a high-quality low-emittance beam. As a result, the high-resolution magnet can be exploited to its full potential with a mass-resolving power  $M/\Delta M$  in the order of  $10^4$ .

## Expected yields

For a first indication, the expected yields at the ISOL@MYRRHA facility are estimated by linearly extrapolating the available production yields listed in the ISOLDE-SC (600 MeV proton beam on UC and ThC targets) and ISAC (500 MeV proton beam on ruggedized spallation targets like Ta, SiC/C, TiC/C, and ZrC/C targets) databases. In this approximation, it is assumed that diffusion and effusion losses, the ion-source efficiencies and the separator-transport efficiencies are the same.

## Physics cases

Measurements with high-intensity beams and long/regular beam times are an important source of information for quasi all fields in science making use of RIBs.

The figure below shows an overview of typical RIB research over the different fields with ISOL@MYRRHA opportunities indicated in red font.

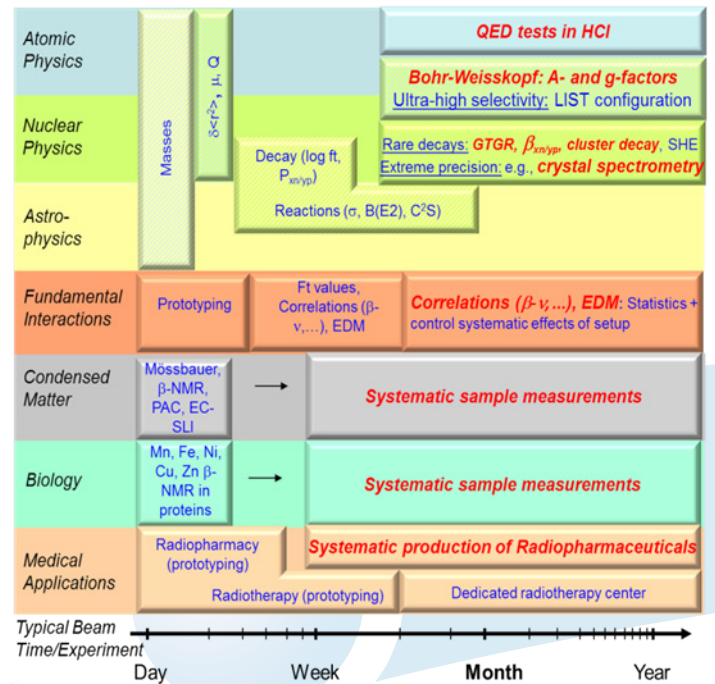

ISOL@MYRRHA yields for alkalis and noble gases from ISOLDE-SC and TRIUMF extrapolations

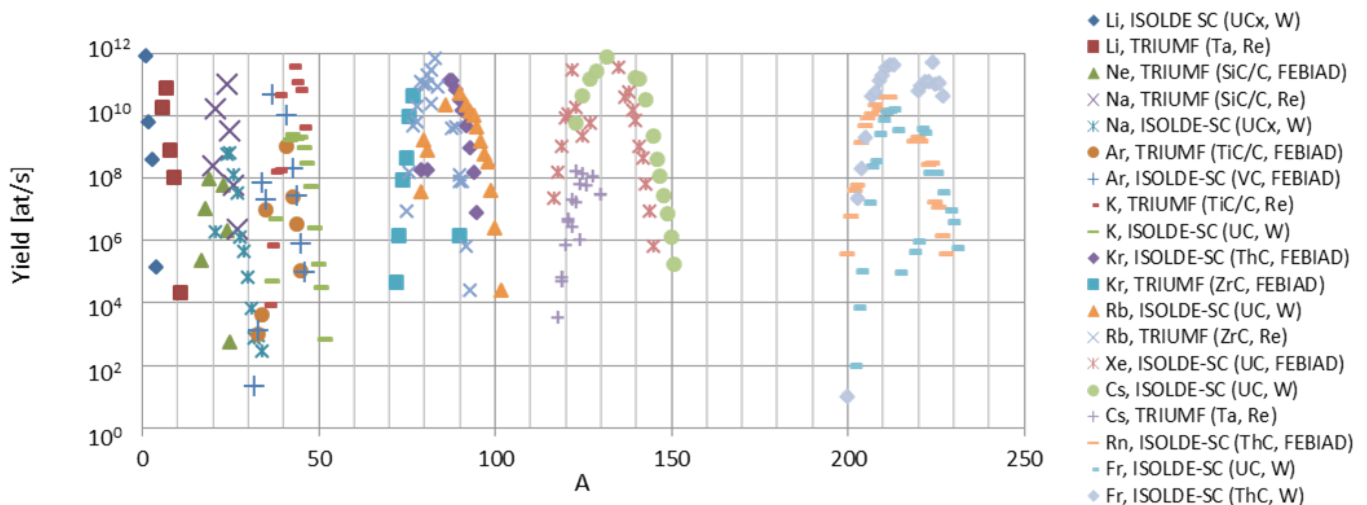

## More information

isolmyrrha@sckcen.be  
<http://isolmyrrha.sckcen.be>